

# NL100LVM

Elevating Work Platform



[www.nifty-lift.com.au](http://www.nifty-lift.com.au)

P: +61 3 9725 0077 | [sales@nifty-lift.com.au](mailto:sales@nifty-lift.com.au)



**ELEVATING**  
WORK PLATFORMS

# NL100LVM

## Elevating Work Platform



Working Height  
**10.3m**



Ground-Basket  
**8.3m**



Rated Capacity  
**120kg**



Working Reach  
**4.7m**



To Basket Edge  
**4m**



Continuous Slew  
**360°**

### Features & Benefits:

- Easy to use push button basket controls with two speed operation.
- High strength double boom design.
- Vertical stabilisers are ideal for quick setup in confined work areas.
- Designed specifically to comply with Australian Standards, including optional low voltage insulation.
- Capable of continuous 360° slew in either direction.
- Compact design to withstand the rigours of industry.
- Emergency controls are provided at the base and an emergency hand pump comes as standard.
- Smooth operation is assured via a mechanical basket levelling system.
- Battery electric powered hydraulic system provides reliable operation, with quick battery recharging via 240v GPO.

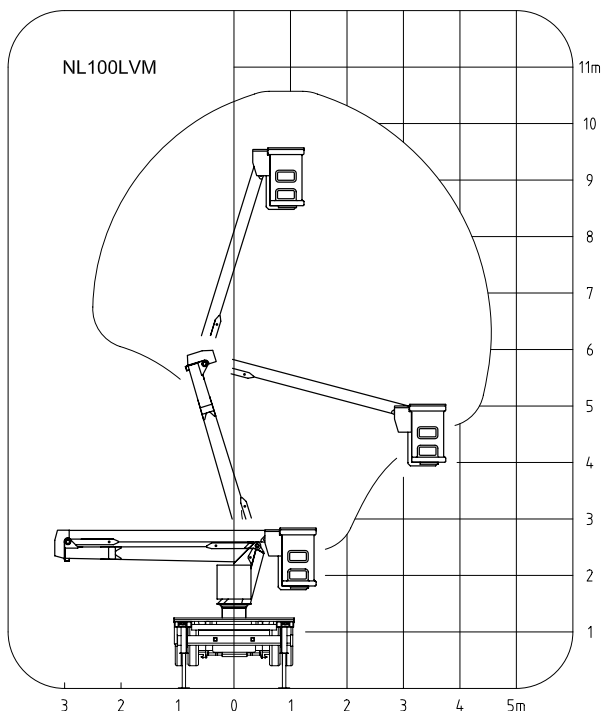

### The NL100LVM – The ‘Access All Areas’ EWP

The versatile NL100LVM is designed for contractors who require a quick and easy to use EWP. Whether it be maintenance, signage or electrical connection works, the NL100LVM offers an outstanding working envelope and excellent onsite flexibility and all from the comfort and practicality that comes with a utility or small car license cab chassis.

#### Optional Accessories

- Low voltage insulation rating to AS1418.10.
- Charging of the batteries via the vehicle alternator which allows for continuous EWP use.
- Extensive range of bodywork options including toolboxes, cone holders, vices, lighting, towbars and cab protection.
- PTO powered pump (truck mounts only).

# NL100LVM

## Advanced Features

Easy to use push button basket control system with emergency stop button

Optimised high strength double boom design for maximum lifespan.

Emergency controls are provided at the base with emergency hand pump

Aluminium tray with drop sides and headboard

Suitable for utility or car license cab chassis - 4x2 and 4x4  
\*GVM upgrade may be required depending on vehicle

Vertical stabilisers for quick setup in confined work areas

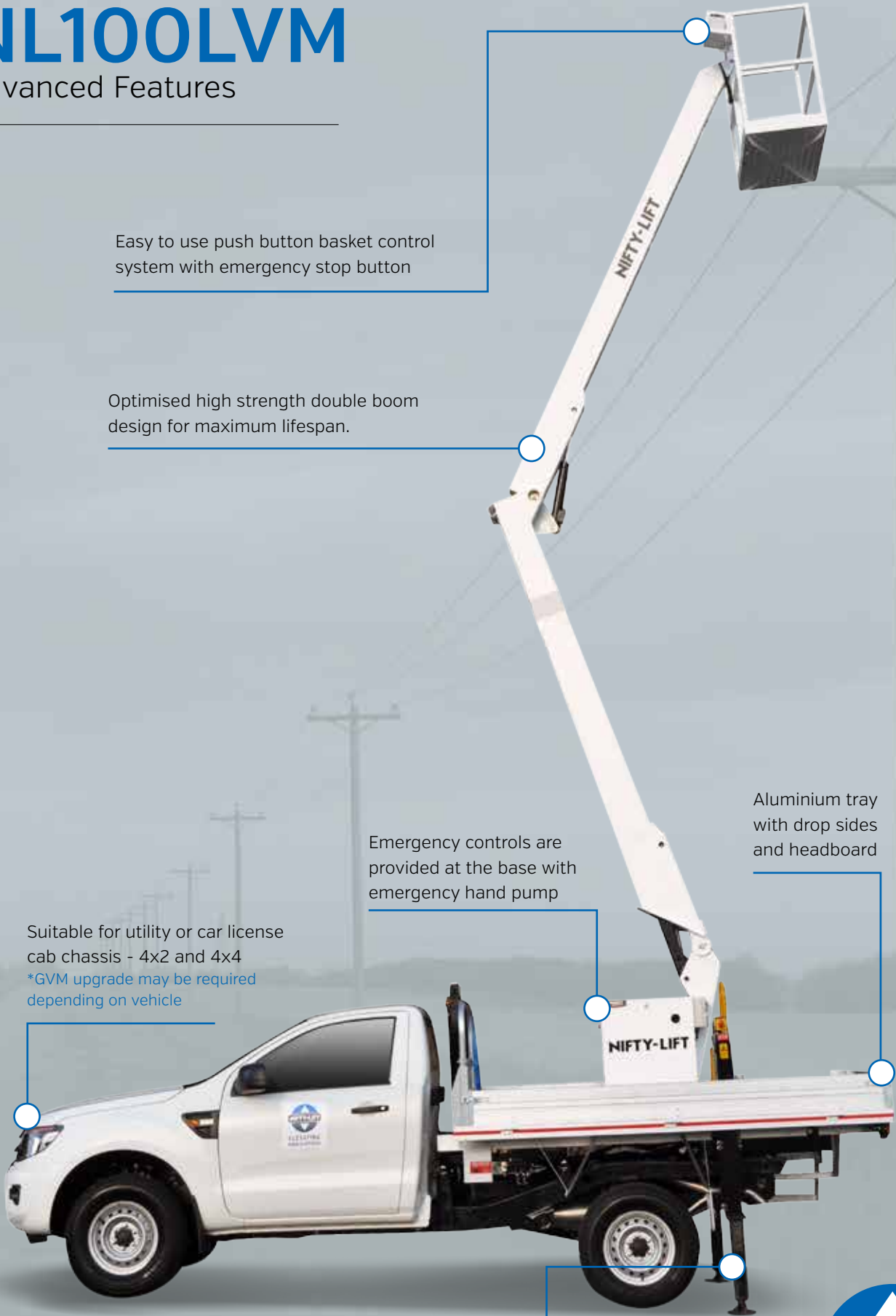

**ELEVATING**  
WORK PLATFORMS

Visit us online for more information at [www.nifty-lift.com.au](http://www.nifty-lift.com.au)

# Why Choose Nifty-Lift?

---

## Designed & Engineered In Australia

Our optimised designs ensure greater job site performance coupled with less downtime, giving you higher productivity and lower cost of ownership over the life of the work platform. Nifty-Lift has over 25 years of experience designing innovative access solutions, and through extensive industry consultation and the use of cutting edge engineering software we have produced a range of industry leading models. Our experience and expertise gives owners and operators piece of mind when working at height in a Nifty-Lift elevating work platform.

## After Sales Support

We support our work platforms through their entire lifecycle, not just under warranty. The team of highly experienced Nifty-Lift service technicians are available to assist operators, fleet owners and workshops with training, advice, documentation and product upgrades. We partner with our customers for life.

## Parts Department

Nifty-Lift stocks thousands of genuine spare parts. We can easily arrange overnight freight for all your spares and service items to ensure your EWP is returned to service with minimal downtime.

*Nifty-Lift reserves the right to alter specifications without notice. Photographs and drawings in this document are for illustrative purposes only. Product shown in photos contains optional features. Nifty-Lift, in so far as it is permitted by law to do so, shall not be liable in any way as a result of any reliance by any person on anything contained in this brochure. Please contact Nifty-Lift for current and detailed specifications.*



**ELEVATING**  
WORK PLATFORMS

[www.nifty-lift.com.au](http://www.nifty-lift.com.au)

P: +61 3 9725 0077 | [sales@nifty-lift.com.au](mailto:sales@nifty-lift.com.au)